

# VC10V系列可编程控制器用户速查手册

本速查手册用于 VC10V 系列 PLC 的设计、安装、连接和维护的快速指引，便于用户现场对所需信息的查阅。简述了 VC10V 系列 PLC 的硬件规格、特性及使用方法。并有相关选配件的简介，常见问题答疑等，便于参考。若需要更详细的产品资料，可参考我公司发行的《VC10V 系列可编程控制器用户手册》、《编程软件用户手册》和《VC 系列小型可编程控制器编程手册》。如需要，可向供货商咨询。您也可以登录我司网站下载 PLC 相关技术资料或反馈 PLC 相关问题。

## 1 产品介绍

### 1.1 型号说明

产品型号说明如下图所示

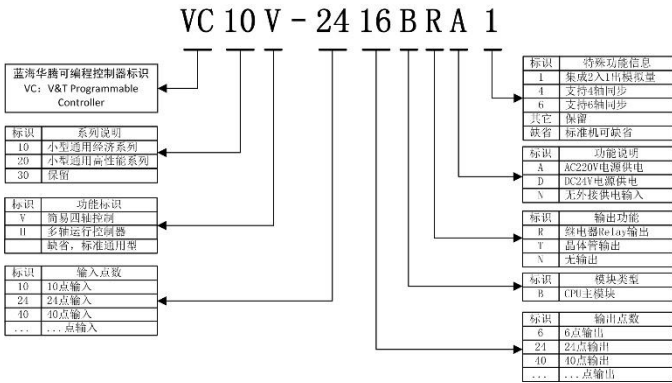

尊敬的用户：

您好！感谢您选用了我司产品。为了解产品在使用中的质量情况，更好地为您服务，请您在设备运行 1 个月时详细填写此表并邮寄或传真给我公司客户服务中心，当我们收到您填写完整的《产品质量反馈单》后，我们将给您寄去一份精美的纪念品，以表示我们的衷心谢意。如您能对我们提高产品和服务质量提出建议，便有机会获得特别奖励。

客户服务中心

## 产品质量反馈单

用户姓名		电话	
用户地址		邮编	
产品名称及型号		安装日期	
机器编号			
产品外观或结构			
产品性能			
产品包装			
产品资料			
使用中质量情况			
您对该产品的改进意见或建议			

## 1.2 外形结构

VC10V 系列主模块的外形结构如下图所示（以 VC10V-1614BRA 为例）。

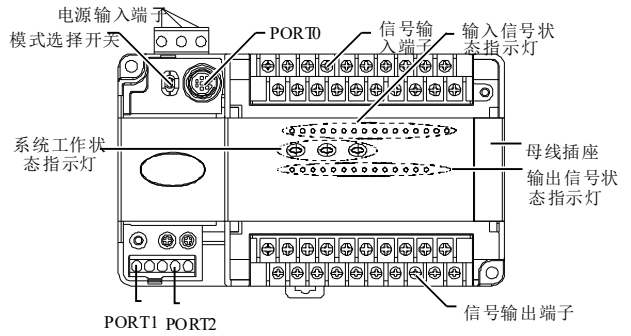

PORT0、PORT1、PORT2 为通讯端口。PORT0 为 RS232 电平，插座为 Mini DIN8。PORT1、PORT2 均为 RS485。母线插座用于连接扩展模块。模式选择开关有 ON、TM、OFF 三个档位。

## 1.3 端子介绍

### 1. 14、20、24 点主模块端子排列

输入端子：

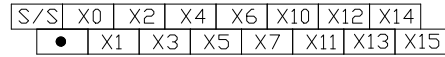

输出端子：

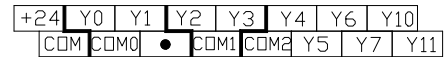

### 2. 30 点主模块端子排列

输入端子：

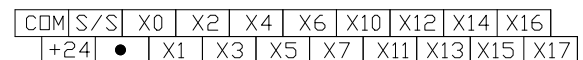

输出端子：

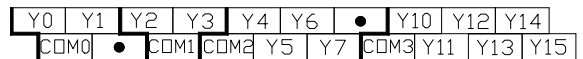

### 3. 40 点主模块端子排列

输入端子：

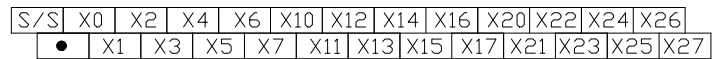

输出端子：

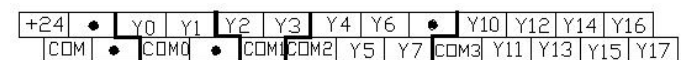

### 4. 60 点主模块端子排列

输入端子：

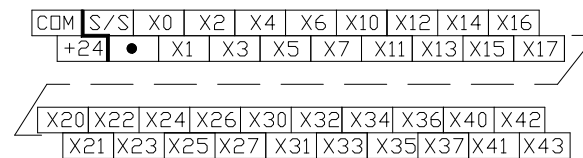

输出端子：

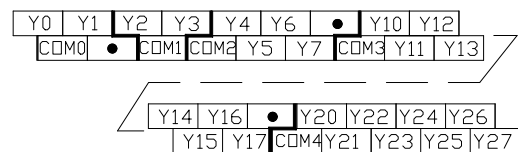

## 5. 30 点模拟量主模块带端子排列

输入端子:

COM	S/S	X0	X2	X4	X6	X10	X12	X14	X16	AVI1-	●	AVI2-
+24	X1	X3	X5	X7	X11	X13	X15	X17	AV1+	AI1+	AV2+	AI2+

输出端子:

Y0	Y1	Y2	Y3	Y4	Y6	●	Y10	Y12	Y14	●	AVO+	AIO+
COM0	●	COM1	COM2	Y5	Y7	COM3	Y11	Y13	Y15	●	AO-	●

## 2 电源规格

主模块内置电源电气规格和主模块可提供给扩展模块的电源规格如下表所示。

项目	单位	最小值	典型值	最大值	备注
输入电压范围	VAC	85	220	264	正常启动和工作范围
输入电流	A	/	/	1.5	90VAC 输入, 满载输出
额定输出电流	5V/GND	mA	/	900	5V/GND、24V/GND 两路输出组合总功率不得超过 10.4W。电源最大输出功率即为各路满载之和, 为 24.8W
	24V/GND	mA	/	300	
	24V/COM	mA	/	600	

## 3 开关量输入输出特性

### 3.1 输入特性与信号规格

输入特性与信号规格如下表所示。

项目	高速输入端 X0~X7	普通输入端
信号输入方式	源型/漏型方式, 用户可通过“S/S”端子进行选择	
电气参数	检测电压	24VDC
	输入阻抗	3.3kΩ
	输入 ON	外部回路电阻小于 400Ω
	输入 OFF	外部回路电阻大于 24kΩ
滤波功能	数字滤波	X0~X7 有数字滤波功能, 滤波时间可在 0ms、8ms、16ms、32ms、64ms 之间由用户编程设定
	硬件滤波	除 X0~X7 以外的其余端口为硬件滤波, 滤波时间约 10ms
高速功能	X0~X7 可实现高速计数、中断、脉冲捕捉等功能	
	X0、X1 端口计数最高频率达 50kHz	
	X2~X5 端口计数最高频率达 10kHz	
公共接线端	只有一个公共端, 为 COM	

计数器输入端口有相应的最高频率限制。当输入频率超过该限制后, 可能导致计数不准, 或系统无法正常运行, 请合理安排输入端口, 选用合适的外部传感器。

PLC 提供一个端口“S/S”用来选择信号的输入方式, 可以设置为源型输入方式或漏型输入方式。将“S/S”与“+24V”相连, 即设置为漏型输入方式, 可以连接 NPN 型传感器。

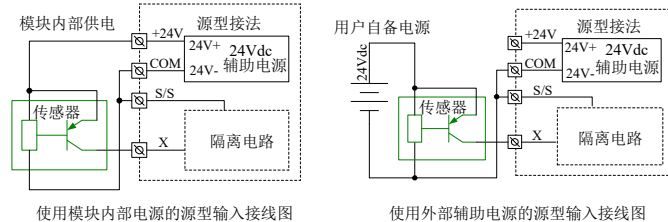

使用模块内部电源的源型输入接线图

使用外部辅助电源的源型输入接线图

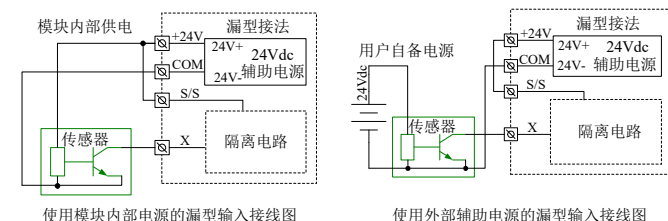

使用模块内部电源的漏型输入接线图

使用外部辅助电源的漏型输入接线图

### 输入连接示例

下图为 VC10V-1614BRA 加一个 VC10-0808ENR 的连接, 实现简单定位控制的示例。由编码器得到的位置信号通过 X0、X1 高速计数端子检测,

需要快速反应的行程开关信号可接入 X2~X7 的高速端子, 其余的用户信号则可分布于输入端口。

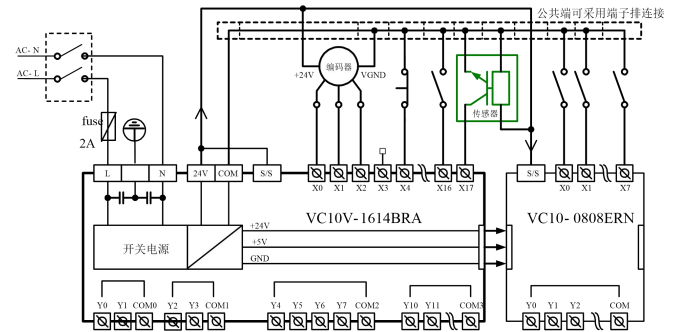

### 3.2 输出特性与信号规格继电器与晶体管两种输出类型的比较如下表所示。

项目	继电器型	晶体管型
输出方式	输出状态为“ON”时导通; 输出状态为“OFF”时断开	
公共端	分有若干组, 每组有一个公共端 COMn, 适应不同电位的控制电路, 各公共端之间绝缘隔离	
电压特性	220VAC、24VDC, 无极性要求	24VDC, 有极性要求
电流要求	按照输出电气规范要求使用	
特点差别	驱动电压高, 电流较大	驱动电流小, 频率高, 寿命长
应用场合	驱动中间继电器、接触器的线圈、指示灯等动作频率不高的负载	控制伺服放大器、频繁动作的电磁铁等要求频率高、寿命长的应用场合

输出电气规范如下表所示。

项目	继电器型输出	晶体管型输出
回路电源电压	250VAC, 30VDC 以下	5~24VDC
电路绝缘	继电器机械绝缘	光耦绝缘
动作指示	继电器输出触点闭合, 指示灯点亮	光耦被驱动时指示灯点亮
开路时漏电流	/	小于 0.1mA/30VDC
最小负载	2mA/5VDC	5mA (5~24VDC)
最大输出电流	电阻负载	Y0/Y1/Y2/Y3: 0.3A/1 点 其他: 0.3A/1 点、0.8A/4 点、1.2A/6 点、1.6A/8 点。8 点以上每增加 1 点允许总电流增加 0.1A
	感性负载	220VAC, 80VA 其他: 12W/24VDC
	电灯负载	220VAC, 100W 其他: 1.5W/24VDC
响应时间	OFF→ON	20ms Max
	ON→OFF	20ms Max
Y0、Y1 最高输出频率	/	每通道 100kHz
Y2、Y3 最高输出频率	/	每通道 10kHz
输出公共端	Y0/Y1—COM0。Y2/Y3—COM1。Y4 以后至多每 8 个端口使用 1 个公共端, 每个公共端之间彼此隔离	
熔断器保护	无	

### 输出连接示例

下图为 VC10V-1614BRA 加一只 VC10-0808ENR 的连接方式, 不同的输出组可接入不同的信号电压回路。有的输出组(如 Y0—COM0)连接在 24VDC 回路, 且由本控制器的 24V-COM 供电。有的输出组(如 Y2—COM1)连接在 5VDC 低电压信号回路。而其它输出组(如 Y4~Y7)连接在 220VAC 交流电压信号回路。即不同的输出组可工作于不同的电压等级回路。

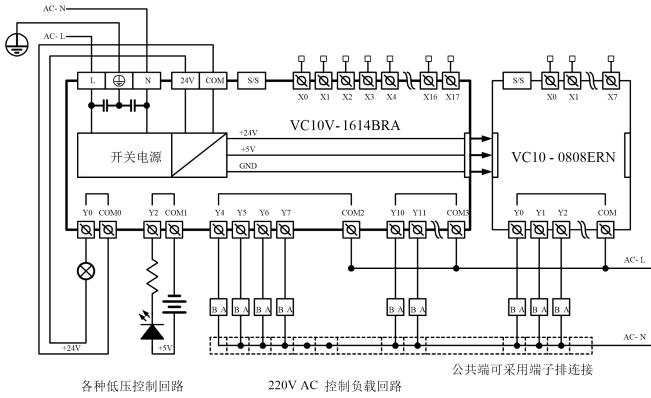

## 5.2 安装方法

### 采用 DIN 槽安装固定

一般情况采用 35mm 宽度的 DIN 槽进行安装，如下图所示。

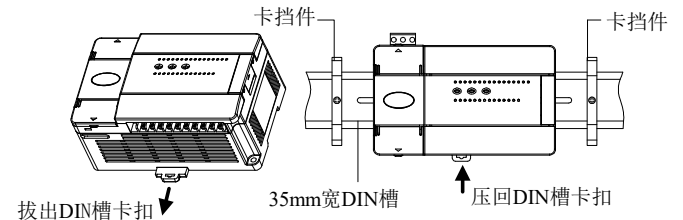

具体的安装步骤如下：

1. 将 DIN 槽水平固定于安装背板上；
2. 将模块底部下方的 DIN 槽卡扣拔出；
3. 把模块挂到 DIN 上；
4. 将卡扣压回原位，锁住模块；
5. 最后再将模块的两端用 DIN 槽卡挡件固定，避免左右滑动。

其他 VC10V 系列可编程控制器均可按上述步骤进行 DIN 槽安装。

### 采用螺钉安装固定

对于可能存在较大冲击的场合，则可采用螺孔安装方式。将固定螺丝经 PLC 外壳的两个螺孔固定在电气柜的背板上，螺丝尺寸 M3。如下图所示。

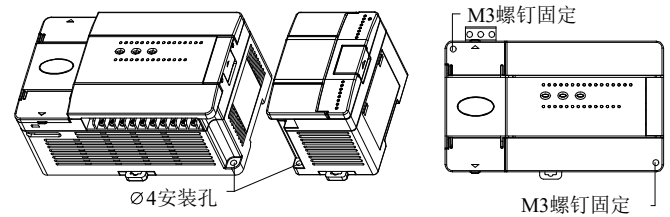

## 5.3 电缆连接及规格

连接电源线及接地线，建议用户在 PLC 电源输入增加空开、fuse 保护电路，交流电源及辅助电源连接示例如下图所示。

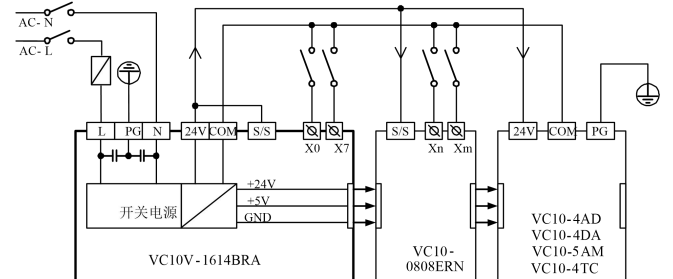

设置可靠的接地线可加强设备安全，提高 PLC 的电磁抗扰能力，安装时将 PLC 的电源端连接到接地体上，建议采用 AWG12~16 型连接导线，并尽可能减小导线长度。

建议设置独立的接地装置，布线中尽量避免与其他设备（尤其是干扰较强的设备）的接地线有公共路径，如下图所示。

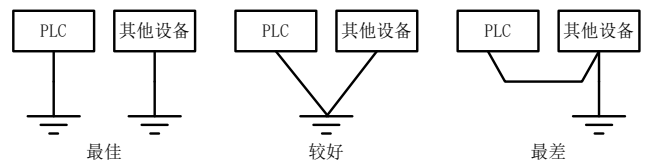

### 电缆规格

在进行 PLC 应用的配线时，建议使用多股铜导线，并预制绝缘端头，这样可以保证接线质量。推荐选用导线的截面积和型号如下表所示。

## 4 通讯口

VC10V 系列 PLC 主模块提供了三个串行异步通讯端口，分别为 PORT0 和 PORT1、PORT2，支持的波特率：115200、57600、38400、19200、9600、4800、2400、1200bps。PORT0 的通讯协议由模式选择开关决定，参见下图。

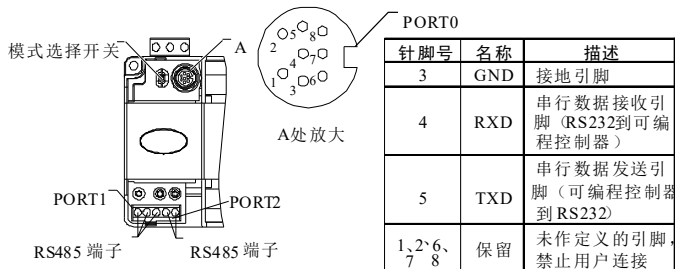

PORT0 作为用户编程的专用接口，可通过模式选择开关强制切换为编程协议。PLC 运行状态及 PORT0 使用协议关系如下表所示。

模式选择开关位置	状态	PORT0 运行协议
ON	运行	由用户程序及其系统配置决定，可为编程协议、MODBUS 协议、自由端口协议、N:N 网络协议
TM (ON→TM)	运行	强制切换为编程口协议
TM (OFF→TM)	停止	
OFF	停止	若用户程序的系统设置为自由口协议，则停止后自动切换为编程口协议，否则保持系统设置的协议不变

PORT1、PORT2 适合与具有通讯功能的生产设备连接使用，如变频器，采用 MODBUS 协议或 RS485 端口自由协议，对多台设备进行组网控制。其端口为螺丝固定的端子，通讯信号电缆可由用户自行制作，建议使用双绞屏蔽线作为通信端口的连接电缆。

## 5 安装

本 PLC 设计用于安装环境 II 标准、污染等级 2 的应用场合。

### 5.1 尺寸规格

型号	长	宽	高	净重
VC10V-0806BRA、 VC10V-0806BTA	135mm	90mm	71.2mm	440g
VC10V-1208BRA、 VC10V-1208BTA				440g
VC10V-1410BRA、 VC10V-1410BTA、 VC10V-1614BRA、 VC10V-1614BTA				470g
VC10V-2416BRA、 VC10V-2416BTA、 VC10V-1614BRA1、 VC10V-1614BTA1、	150mm	90mm	71.2mm	650g
VC10V-3624BRA、 VC10V-3624BTA	182mm	90mm	71.2mm	750g
	224.5m m	90mm	71.2mm	950g

线缆	导线截面	推荐导线号	配合使用的接线端子及热缩管
交流电源线 (L、N)	1.0~2.0mm <sup>2</sup>	AWG12、18	H1.5/14 预绝缘管状端头，或线头烫锡处理
接地线 (⊕)	2.0mm <sup>2</sup>	AWG12	H2.0/14 预绝缘管状端头，或线头烫锡处理
输入信号线 (X)	0.8~1.0mm <sup>2</sup>	AWG18、20	UT1-3 或 OT1-3 冷压端头，
输出信号线 (Y)	0.8~1.0mm <sup>2</sup>	AWG18、20	Φ3 或 Φ4 热缩管

将加工好的电缆头用螺丝固定在 PLC 的接线端子上，注意螺钉位置正确，螺钉的旋紧力矩在 0.5~0.8Nm，保证可靠连接，又不致损坏螺丝。

推荐的电缆制备方式如下图所示。

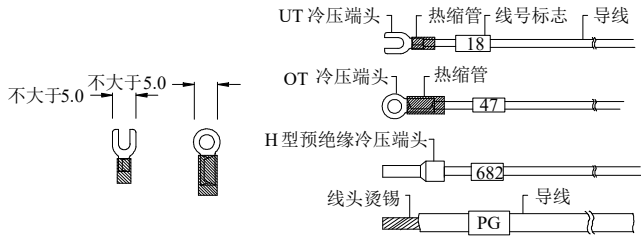

## 6 上电运行与例行保养

### 6.1 上电运行

接线完毕后逐项检查连接情况，确保无异物掉入机壳内，散热通畅。

1. 接通 PLC 电源，PLC 的 POWER 灯应点亮。
2. 启动 PC 上的软件，将编制好的用户程序下载到 PLC。
3. 下载程序校验完毕，把模式选择开关拨到 ON 位，RUN 灯应点亮，若 ERR 灯点亮，表明用户程序或系统有错误，请按《VC 系列小型可编程控制器编程手册》的说明排除错误，直到正确为止。
4. 再把 PLC 外部系统的电源合上，进行系统调试。

### 6.2 例行保养

例行保养检查应注意如下方面：

1. 保证 PLC 控制器工作环境的整洁，避免异物、灰尘落入机内；
2. 保持可编程控制器良好的通风散热；
3. 所有接线连接及接线端子固定牢固，状态良好。

3 继电器触点只能连接小于 2A 的负载。需要接通更大负载时，请在外部使接触器或中间继电器。

4 当继电器触点电流过小时，不能保证其可靠导通。建议设计触点电流大于 5mA。

### 用户须知

1. 保修范围指可编程控制器本体。
2. 保修期为十八个月，保修期内正常使用情况下，产品发生故障或损坏，我公司免费维修。
3. 保修期起始时间为产品制造出厂日期，机器编码是判断保修期的唯一依据，无机器编码的设备按过保处理。
4. 即使在保修期内，如发生以下情况，将收取一定的维修费用：  
不按用户手册操作导致的机器故障；  
由于火灾、水灾、电压异常等造成的机器损坏；  
将可编程控制器用于非正常功能时造成的损坏。
5. 服务费按实际费用计算，如另有合同，以合同优先的原则处理。
6. 请您务必保留此卡，并在保修时出示给维修单位。
7. 如您有问题可与代理商联系，也可直接与我公司联系。

版权所有，保留一切权利。内容如有改动，恕不另行通知。

## VC10V Series PLC Quick Start User Manual

This quick start manual is to offer you a quick guide to the design, installation, connection and maintenance of VC10V series PLC, convenient for on-site reference. Briefly introduced in this booklet are



- 1 晶体管输出严禁接交流回路，如 220VAC。请严格参照电气参数要求设计输出回路，不可过压或过流。
- 2 继电器触点频繁操作会严重影响其使用寿命，请合理使用。

the hardware specs, features, and usage of VC10V series PLC, plus the optional parts and FAQ for your reference. For detailed product information, please refer to our *VC10V Series Micro-PLC Programming Manual*. For ordering the above user manuals, contact your distributor or sales office.

## 1 Introduction

### 1.1 Model Designation

The model designation is shown in the following figure.

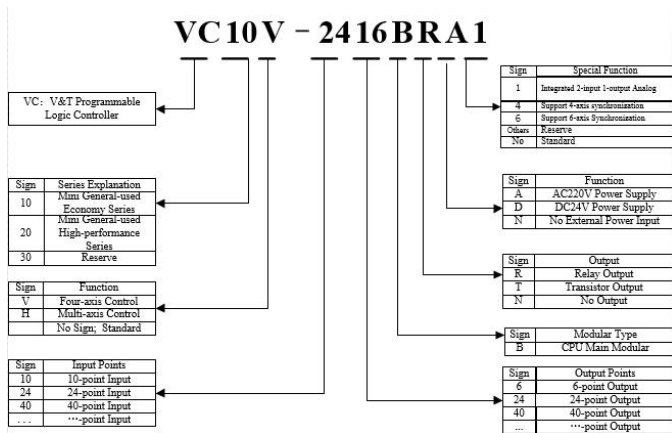

### To Customers:

Thank you for choosing our products. To improve the product and provide better service for you, could you please fill in the form after the product has been operated for 1 month, and mail or fax it to our Customer Service Center? Thank you very much!

### Product Quality Feedback Form

Customer name		Tele	
Address		Zip code	
Model		Date of use	
Machine SN			
Appearance or structure			
Performance			
Package			
Material			
Quality problem during usage			
Suggestion about improvement			

### 1.2 Outline

The outline of the basic module is shown in the following figure by taking the example of VC10V-1614BRA.

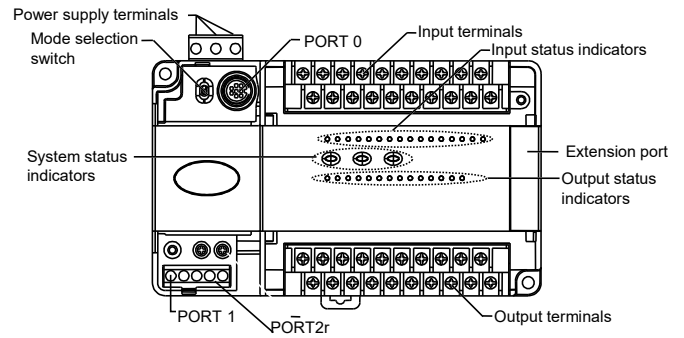

PORT0 and PORT1 are communication terminals. PORT0 uses RS232 mode with Mini DIN8 socket. PORT1 and PORT2 uses RS485 mode. The busbar socket is for connecting the extension module. The mode selection switch has three positions: ON, TM and OFF.

### 1.3 Terminal Introduction

The layouts of terminals of different I/O points are shown below:

#### 1) 14 20-point

Input terminal:

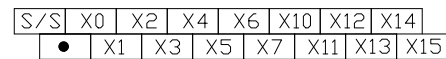

Output terminal:

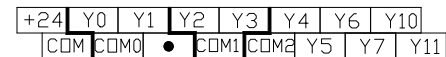

#### 2) 24-point

Input terminal:

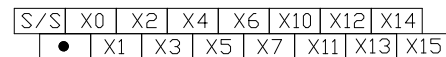

Output terminal:

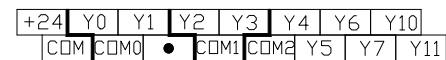

#### 3) 30-point

Input terminal:

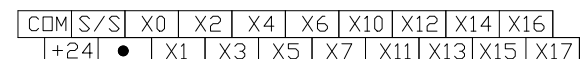

Output terminal:

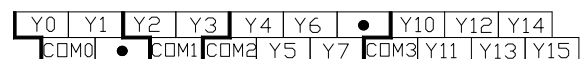

#### 4) 40-point

Input terminal:

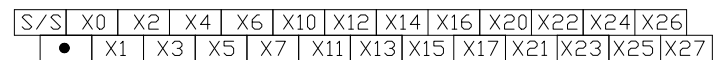

Output terminal:

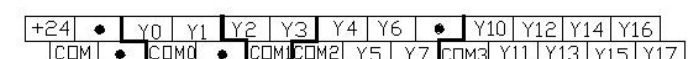

#### 5) 60-point

Input terminal:

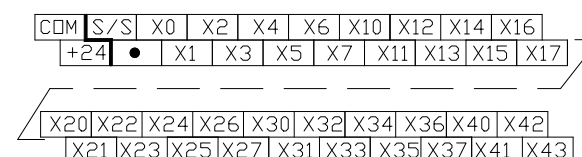

Output terminal:

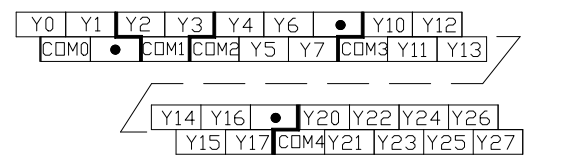

6) 30-point (including analog signal terminals)

Input terminal:

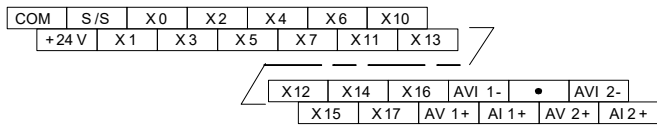

Output terminal:

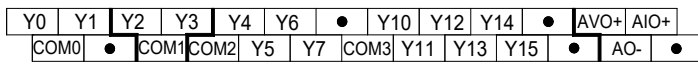

## 2 Power Supply

The specification of PLC built-in power and power for extension modules is listed in the following table.

Item	Unit	Min.	Rated	Max.	Note
Power supply voltage	Vac	85	220	264	Normal startup and operation
Input current	A	/	/	1.5	Input: 90Vac, 100% output
Output current	5V/GND	mA	/	900	The total power of outputs 5V/GND and 24V/GND ≤ 10.4W. Max. output power: 24.8W (sum of all branches)
	24V/GND	mA	/	300	
	24V/COM	mA	/	600	

## 3 Digital Inputs & Outputs

### 3.1 Input Characteristic And Specification

The input characteristic and specs are shown as follows:

Item	High-speed input terminals X0~X7	General input terminal
Input mode	Source mode or sink mode, set through s/s terminal	
Electric parameters	Input voltage	24Vdc
	Input impedance	3.3kΩ / 4.3kΩ
	Input ON	External circuit resistance < 400Ω
	Input OFF	External circuit resistance > 24kΩ
Filtering function	Digital filter	X0~X17 have digital filtering function. Filtering time: 0, 8, 16, 32 or 64ms (selected through user programme)
	Hardware filter	Input terminals other than X0 ~ X17 are of hardware filtering. Filtering time: about 8ms
High-speed function	X0~X7: high-speed counting, interrupt, and pulse catching X0 and X1: up to 100kHz counting frequency X2~X5: up to 10kHz counting frequency The sum of input frequency should be less than 400kHz	
Common terminal	Only one common terminal: COM	

The input terminal act as a counter has a limit over the maximum frequency. Any frequency higher than that may result in incorrect counting or abnormal system operation. Make sure that the input terminal arrangement is reasonable and external sensors used are proper.

Input connection example

The following diagram shows an example of VC10V-1614BRA in connection with an VC10-0808ERN, which realizes simple positioning control. The positioning signals from the PG are input through high speed counting terminals X0 and X1, the limit switch signals that require high-speed response can be input through high-speed terminals X2 ~ X7. Other user signals can be input through any other input terminals.

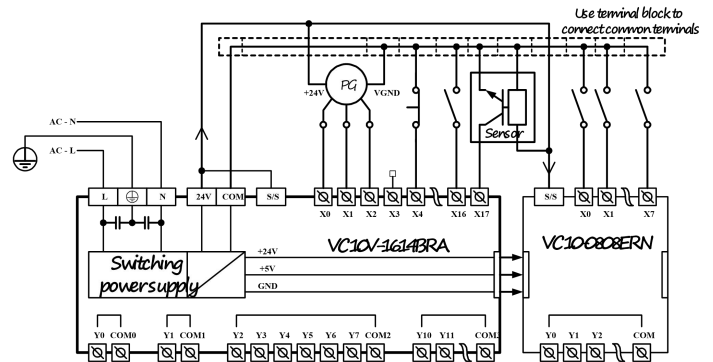

### 3.2 Output Characteristic And Specification

The following table shows the relay output and transistor output.

Item	Relay output	Transistor output
Output mode	When output state is ON, the circuit is closed; OFF, open	
Common terminal	Divided into multiple groups, each with a common terminal COMn, suitable for control circuits with different potentials. All common terminals are isolated from each other	
Voltage	220Vac; 24Vdc, no polarity requirement	24Vdc, correct polarity required
Current	Accord with output electric specs (see following Table )	
Difference	High driving voltage, large current	Small driving current, high frequency, long lifespan
Application	Loads with low action frequency such as intermediate relay, contactor coil, and LEDs	Loads with high frequency and long life, such as control servoamplifier and electromagnet that action frequently

The electric specs of outputs is shown in the following table.

Item	Relay output terminal	Transistor output terminal
Switched voltage	Below 250Vac, 30Vdc	5~24Vdc
Circuit isolation	By Relay	PhotoCoupler
Operation indication	Relay output contacts closed, LED on	LED is on when optical coupler is driven
Leakage current of open circuit	/	Less than 0.1mA/30Vdc
Minimum load	2mA/5Vdc	5mA (5~24Vdc)
Max. output current	Resistive load	Y0, Y1: 0.3A/1 point; Others: 0.3A/1 point, 0.8A/4 point, 1.2A/6 point, 1.6A/8 point. Above 8 points, total current increases 0.1A at each point increase
	Inductive load	Y0, Y1: 7.2W/24Vdc Others: 12W/24Vdc
	Illumination load	Y0, Y1: 0.9W/24Vdc Others: 1.5W/24Vdc
Response time	OFF→ON	20ms Max
	ON→OFF	20ms Max
Y0, Y1 max. output frequency	/	Each channel: 100kHz
Output common terminal	Y0 Y1-COM0; Y2 Y3-COM1. After Y3, every 8 terminals use one isolated common terminal	
Fuse protection	No	

Output connection example

The following diagram shows an example of VC10V-1614BRA in connection with an VC10-0808ERN. Different output groups can be connected to different signal circuits with different voltages. Some (like Y0-COM0) are connected to the 24Vdc circuit powered by local 24V-COM, some (like Y2-COM1) are connected to the 5Vdc low voltage signal circuit, and others (like Y4~Y7) are connected to the 220Vac voltage signal circuit.

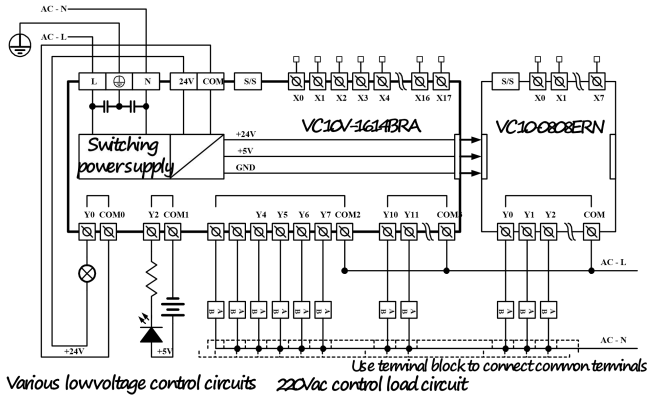

115200 bps      57600 bps      38400 bps      19200 bps  
 9600 bps      4800 bps      2400 bps      1200 bps

The mode selection switch determines the communication protocol.

As a terminal dedicated to user programming, PORT0 can be converted to programming protocol through the mode selection switch. The relationship between PLC operation status and the protocol used by PORT0 is shown in the following table.

Mode selection switch position	status	PORT0 operation protocol
ON	Running	Programming protocol, or Modbus protocol, or free-port protocol, or N: N network protocol (ECBUS), as determined by user program and system configuration
ON→TM	Running	Converted to programming protocol
OFF→TM	Stop	
OFF	Stop	If the system configuration of user program is free-port protocol, it converts to programming protocol automatically after stop; or system protocol keeps unchanged

PORT1 and PORT2 is ideal for connection with equipment that can communicate (such as inverters). With Modbus protocol or RS485 terminal free protocol, it can control multiple devices through the network. Its terminals are fixed with screws. You can use a shielded twisted-pair as the signal cable to connect communication ports by yourself.

## 6 Installation

PLC is applicable to Installation category II, Pollution degree 2.

### 6.1 Installation Dimensions

Model	Length	Width	Height	Weight
VC10V-1006BRA VC10V-1006BTA	135mm	90mm	71.2mm	440g
VC10V-1410BRA VC10V-1410BTA	135mm	90mm	71.2mm	470g
VC10V-1614BRA VC10V-1614BTA	150mm	90mm	71.2mm	520g
VC10V-2416BRA VC10V-2416BTA VC10V-1614BRA1 VC10V-1614BTA1	182mm	90mm	71.2mm	590g
VC10V-3624BRA VC10V-3624BTA	224.5mm	90mm	71.2mm	650g

### 6.2 Installation Method

#### DIN rail mounting

Generally you can mount the PLC onto a 35mm-wide rail (DIN), as shown in the following figure.

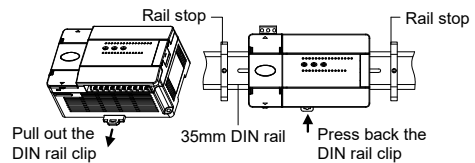

#### Screw fixing

Fixing the PLC with screws can stand greater shock than DIN rail mounting. Use M3 screws through the mounting holes on PLC enclosure to fix the PLC onto the backboard of the electric cabinet, as shown in the following figure.

## 4 Analog Inputs & Outputs

### 4.1 Usage Of Analog Terminals

VC10V series PLC provides the basic module with integrated AD/DA function, serving as a small-scale total solution with low cost for users who need to control the analog signal.

PLCs that support input and output of analog signals are listed below:

Model	Analog input			Analog output		
	Channel number	V input	I input	Channel number	V input	I input
VC10V-1614BRA1	2	✓	✓	1	✓	✓
VC10V-1614BTA1	2	✓	✓	1	✓	✓

The user terminals related to analog signals are defined below.

	Terminal	Note	Terminal	Note		
Analog input	AV1+	Input CH1: voltage input	Analog output	AVO+	Output CH: volt signal output	
	AI1+	Input CH1: current input		AIO+	Output CH: current output	
	AV1-	Input CH1: common ground		AO-	AO-	Output CH: common GND
	AV2+	Input CH2: voltage input				
	AI2+	Input CH2: current input				
	AVI2-	Input CH2: common ground				

#### Note:

Never input voltage signal and current signal to the same channel simultaneously. When measuring the current signal, short the voltage signal input terminal with the current signal input terminal

### 4.2 Analog Signal Input & Output Specs

The analog signal input and output specs is listed in the following table.

Item	Description	
Max. conversion speed	AD conversion	4ms/2 channels
	DA conversion	4ms/channel
Analog input range	Voltage input	0 ~ 10Vdc (input impedance ≥ 200kΩ), input signal freq. <10Hz. Warning: the unit could be damaged with input voltage >±15Vdc
	Current input	0 ~ 20mA (input impedance: 250Ω), input signal freq. <10Hz. Warning: the unit could be damaged with input voltage >±30mA
Analog output range	Voltage output	0~10Vdc(external load impedance:2kΩ~1MΩ)
	Current output	0 ~ 20mA (external load impedance: ≤ 500Ω)
Digital range	0 ~ 10000	
Resolution	Voltage I/O	5mV
	Current I/O	10μA
Total precision	Analog input	DC 0 ~ 10V, 0 ~ 20mA: ±1%
	Analog output	±1%
Isolation	Between analog circuit and digital circuit: optical coupler. Between analog channels: none	

## 5 Communication Port

VC10V series PLC basic module has two serial asynchronous communication ports: PORT0,1, and PORT2. Supported baud rates:



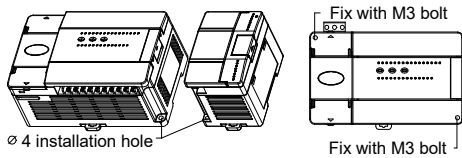

### 6.3 Cable Connection And Specification

#### Connecting power cable and grounding cable

The connection of AC power and auxiliary power is demonstrated in the following figure.

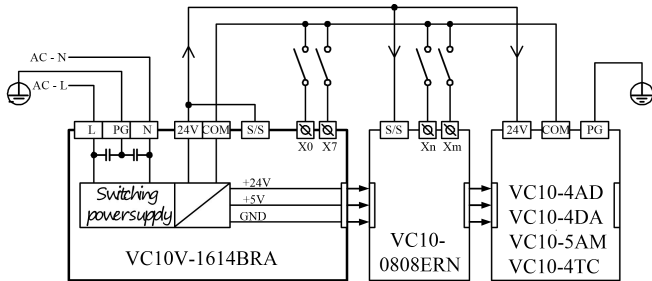

Connect the PLC terminal to the grounding electrode. To ensure reliable grounding cable connection, which makes the equipment safer and protects it from EMI, use AWG12~16 cable, and make the cable as short as possible. Use independent grounding. Avoid sharing route with the grounding cable of other equipment (particularly those with strong EMI). See the following figure.

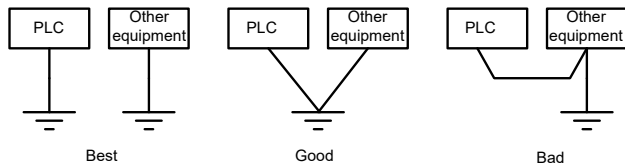

#### Cable specification

When wiring a PLC, use multi-strand copper wire and ready-made insulated terminals to ensure the quality. The recommended model and the cross-sectional area of the cable are shown in the following table.

Wire	Cross-sectional area	Recommended model	Cable lug and heat-shrink tube
AC power cable (L, N)	1.0~2.0mm <sup>2</sup>	AWG12, 18	H1.5/14 round insulated lug, or tinned cable lug
Earth cable (⊕)	2.0mm <sup>2</sup>	AWG12	H2.0/14 round insulated lug, or tinned cable end
Input signal cable (X)	0.8~1.0mm <sup>2</sup>	AWG18, 20	UT1-3 or OT1-3 solderless lug
Output signal cable (Y)	0.8~1.0mm <sup>2</sup>	AWG18, 20	Φ3 or Φ4 heat shrinkable tube

Fix the prepared cable head onto the PLC terminals with screws. Fastening torque: 0.5~0.8Nm.

The recommended cable processing-method is shown in the following figure.

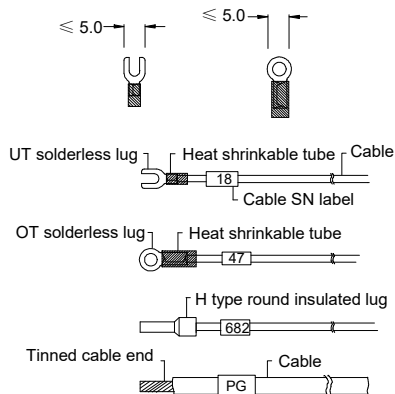

## 7 Power-on Operation And Maintenance

### 7.1 Startup

Check the cable connection carefully. Make sure that the PLC is clear of alien objects and the heat dissipation channel is clear.

1. Power on the PLC, the PLC POWER indicator should be on.
2. Start the software on the host and download the compiled user program to the PLC.
3. After checking the download program, switch the mode selection switch to the ON position, the RUN indicator should be on. If the ERR indicator is on, the user program or the system is faulty. Loop up in the *VC10V series PLC Programming Manual* and remove the fault.
4. Power on the PLC external system to start system debugging.

### 7.2 Routine Maintenance

Do the following:

1. Ensure the PLC a clean environment. Protect it from aliens and dust.
2. Keep the ventilation and heat dissipation of PLC in good condition.
3. Ensure that the cable connections are reliable and in good condition.



#### Warning

1. Never connect the transistor output to an AC circuit (like 220Vac). The design of the output circuit must abide by the requirements of electric parameters, and no over-voltage or over-current is allowed.
2. Use the relay contacts only when necessary, because the life span of relay contacts depends largely on its action times.
3. The relay contacts can support loads smaller than 2A. To support larger loads, use external contacts or mid-relay.
4. Note that the relay contact may fail to close when the current is smaller than 5mA.

#### Notice

1. The warranty range is confined to the PLC only.
2. **Warranty period is 18 months**, within which period Myiter Control Technology conducts free maintenance and repairing to the PLC that has any fault or damage under the normal operation conditions.
3. **The start time of warranty period is the delivery date of the product**, of which the product SN is the sole basis of judgment. PLC without a product SN shall be regarded as out of warranty.
4. Even within 18 months, maintenance will also be charged in the following situations:
  - Damages incurred to the PLC due to mis-operations, which are not in compliance with the User Manual;
  - Damages incurred to the PLC due to fire, flood, abnormal voltage, etc;
  - Damages incurred to the PLC due to the improper use of PLC functions.
5. The service fee will be charged according to the actual costs. If there is any contract, the contract prevails.
6. Please keep this paper and show this paper to the maintenance unit when the product needs to be repaired.
7. If you have any question, please contact the distributor or our company directly.

All rights reserved. The contents in this document are subject to change without notice.